

SECTION 7 – SIGN REGULATIONS

7.1 SIGN PERMIT

7.1.1 Sign Permit Required:

To ensure compliance with these Regulations, a sign permit shall be required in order to erect, move, alter, reconstruct or repair any permanent or temporary sign, except as provided in Section 7.1.7.

7.1.2 Application for a Sign Permit:

Applications for sign permits shall be made in writing on forms furnished by the Planning Department. The application shall contain:

7.1.2.1 The location by street number and the legal description of the proposed sign structure;

7.1.2.2 Names and addresses of the owner, sign contractor and erectors;

7.1.2.3 Legible site plans which include the specific location of the sign and setbacks to adjacent property lines and buildings;

7.1.2.4 A detailed drawing indicating the dimensions, materials, and colors of the proposed sign structure. A certification by a structural engineer may be required by the Planning Department for a freestanding or projecting sign;

7.1.2.5 A graphic drawing or photograph of the sign copy;

7.1.2.6 A description of the lighting to be used, if applicable;

7.1.2.7 Proof of public liability insurance covering freestanding signs and projecting wall signs;

7.1.2.8 If the sign is to be located off the premises advertised, a written lease or permission from the property owner of the site on which the sign will be located; and

7.1.2.9 Sign permit fee and plan check fee as established by the Board of County Commissioners. The applicant shall pay all costs billed by the County relative to the review of the application.

7.1.3 Staff Review and Approval:

7.1.3.1 Within a reasonable time of the date of application submission, the Planning Department shall either certify the application is complete and in compliance of all submittal requirements or reject it as incomplete and notify the applicant in writing of any deficiencies.

7.1.3.2 When the Planning Department has determined the application to be complete, the Planning Department shall review the sign permit in accordance with the established review criteria and has the authority to approve, approve with conditions or deny the

sign permit. Upon the Planning Department’s approval of the sign permit, the sign permit and any building or electrical permits required for the sign shall be issued to the applicant.

7.1.4 Sign Permit Review Criteria:

The following review criteria will be used by the Planning Department to evaluate all sign permit applications:

7.1.4.1 Sign meets the requirements of these Regulations;

7.1.4.2 Sign conforms to the requirements of the building and electrical code;

7.1.4.3 Sign conforms to the size, height, material and location requirements for the zoning district in which it is located;

7.1.4.4 Sign would not interfere with pedestrian or vehicular safety;

7.1.4.5 Sign would not detract from the character of an architecturally significant or historic structure;

7.1.4.6 Sign would not be located so as to have a negative impact on adjacent property;

7.1.4.7 Sign would not detract from the pedestrian quality of street or area; and

7.1.4.8 Sign would not add to an over-proliferation of signs on a particular property or area.

7.1.5 Appeal of Sign Permit Denial or Approval with Conditions:

Any appeal of the Planning Department’s denial of a sign permit or approval with conditions shall be made to the Board of Adjustment as provided in these Regulations.

7.1.6 Sign Variance:¹

Any request for an increase in the maximum allowable area for a sign, or for signs not expressly permitted in these Regulations, must be approved through a variance granted by the Board of Adjustments.

7.1.7 Exemptions:

The following types of signs are exempt from permit requirements of these Regulations and may be placed in any zoning district subject to the provisions of these Regulations. Such signs shall otherwise be in conformance with all applicable requirements contained in these Regulations. All such signs (except government signs) shall be located outside a street right-of-way. Signs shall not interfere with traffic signs or the sight distance triangle at intersections. Evidence of owner’s permission to install sign may be required if Archuleta County checks for the sign’s compliance with these Regulations. All other signs shall be allowed only with permit and upon proof of compliance with these Regulations.

¹ Amended Oct 2021 (Res. 2021-76)

- 7.1.7.1** Signs that are not visible beyond the boundaries of the lot or parcel upon which they are located and/or from any public thoroughfare or right-of-way shall be exempt from the provisions of these Regulations, except that such signs shall be subject to the safety regulations of the Uniform Building Code and the National Electrical Code.
- 7.1.7.2** Non-illuminated address signs not to exceed two (2) square feet in area which identify the address and/or occupants of a dwelling unit or of an establishment.
- 7.1.7.3** Banners applied to paper, plastic or fabric used to decorate or attract attention to a business establishment, provided:
- (1)** The signs are displayed in conjunction with a grand opening celebration for a period not to exceed thirty (30) days, or
 - (2)** The signs are displayed in conjunction with a special sale for a period not to exceed thirty (30) days.
 - (3)** The signs are displayed no more than two (2) times per calendar year per establishment.
 - (4)** The banner shall be securely attached to the wall of the establishment, freestanding signs or light poles on private property.
 - (5)** One (1) banner per street frontage per establishment shall be permitted.
- 7.1.7.4** Non-illuminated signs constructed of metal or masonry which are permanently affixed to buildings or structures for the purpose of identifying the name of a building, date of erection or other historical information as approved by the Planning Department.
- 7.1.7.5** Bulletin board signs not exceeding fifteen (15) square feet in gross surface area accessory to a church, school, or public or nonprofit institution.
- 7.1.7.6** Temporary construction signs provided that:
- (1)** Signs in conjunction with any residential use shall not exceed eight (8) square feet each.
 - (2)** Signs in conjunction with all other uses shall have a maximum area of thirty-two (32) square feet each.
 - (3)** Only one (1) such sign oriented per street front per premises shall be erected. Any two such signs located on the same premises shall be located at least one hundred (100) feet apart as measured by using a straight line.
 - (4)** Such signs shall not be illuminated.
 - (5)** Such signs shall only appear at the construction site.

- (6) Such signs shall be removed within seven (7) days after completion of the project.

7.1.7.7 Temporary decorations or displays, when such are clearly incidental to and are customarily and commonly associated with any national, state, local or religious holiday or celebration; provided that such signs shall be displayed for not more than sixty (60) days in any one (1) year; and may be of any type, number, area, height, location, illumination or animation.

7.1.7.8 On-premise directional and instructional signs not exceeding six (6) square feet in area apiece.

7.1.7.9 Signs affixed to door glass which identify the name and/or address of an establishment.

7.1.7.10 Temporary farm product signs provided that:

- (1) One (1) on-premises sign may be used. Said sign shall be located off the street right-of-way and at least ten (10) feet away from any side lot line. Such sign shall have a maximum area of nine (9) square feet and may not be illuminated.
- (2) A maximum of two (2) off-premises signs shall be permitted. Said off-premise signs may be no greater than four (4) square feet apiece and shall not be illuminated. No such sign shall be allowed in the street right-of-way nor within ten (10) feet of a side lot line.

7.1.7.11 Flags, crests or banners of nations, or organizations of nations, or states and cities, or professional fraternal, religious, or civic organizations, except when displayed in connection with commercial promotion.

7.1.7.12 Signs which advertise a private garage or yard sale on the lot on which the sign is located; provided such signs are displayed no more than twice per year per dwelling unit for a period not to exceed three (3) days.

7.1.7.13 Temporary or permanent signs erected by the County, public utility companies, oil and gas companies, or construction companies to warn of danger or hazardous conditions, including signs indicating the presence of underground cables, gas lines and similar devices.

7.1.7.14 Memorial signs, plaques or grave markers which are noncommercial in nature.

7.1.7.15 Identification signs for any oil and gas operation.

7.1.7.16 Political signs displayed on private property in accordance with an official election or signs erected on behalf of candidates for public office provided:

- (1) The total area of all such signs on a lot does not exceed sixteen (16) square feet.

- (2) All such signs may be erected no sooner than sixty (60) days in advance of the election for which they were made.
- (3) The signs are removed within seven (7) days after the election for which they were made.
- (4) The property owner upon whose land the sign is placed shall give written permission to the person placing said signs and will be responsible for violations.

7.1.7.17 Signs which identify restrooms, public telephones or provide instructions as required by law or necessity, provided the sign does not exceed two (2) square feet in area or as approved by the Planning Department and is non-illuminated, internally illuminated or indirectly illuminated. (This category shall be interpreted to include such signs as “no smoking,” “restrooms,” “no solicitors,” “self-service” and similar informational signs.)

7.1.7.18 Religious symbols located on a building or lot used for organized religious services.

7.1.7.19 Regulatory signs erected on private property, such as “no trespassing” signs, which do not exceed two (2) square feet per face or four (4) square feet in total surface area.

7.1.7.20 “Ranch Watch” and “Neighborhood Crime Watch” signs erected by the County Sheriff’s Department.

7.1.7.21 Temporary signs used to offer for sale, lease or rent the land or buildings upon which the sign is located provided:

- (1) One (1) sign per street frontage advertising real estate (“For Sale”, “For Rent”, “For Lease” or “For Development”) not greater than eight (8) square feet in area in a residential district and thirty-two (32) square feet in area in nonresidential districts may be located on the property being advertised so long as said sign is located behind the street right-of-way line. If the property so advertised lies on a corner lot or double frontage lot, then a second sign may be oriented along the second street so long as the two signs are at least one hundred (100) feet apart as measured by the shortest straight line.
- (2) In addition to the on-site real estate sign(s), a maximum of three (3) directional signs, each not exceeding four (4) square feet in area, shall be permitted off the subject premises. Such signs must be placed outside all existing right-of-ways. The message of said signs shall be limited to the name of the property or development being advertised, an address, a telephone number, a directional arrow, mileage to the subject property, and the terms “Lot/Home For Sale”, “For Rent”, “For Lease”, “For Development”, etc.
- (3) No more than three (3) temporary directional signs advertising a specific planned commercial or mixed use development, subdivision, multi-family development, etc. may also be permitted offsite. Each such sign may have a maximum area of four (4) square feet and shall be placed outside all existing right-of-ways.

(4) All such temporary signs shall be removed within seven (7) days after the real estate closing or lease transaction.

(5) No sign allowed under this subsection shall be lighted.

7.1.7.22 Scoreboards for athletic fields.

7.1.7.23 Temporary special event signs and banners for religious, charitable, civic, fraternal or similar non-profit or not-for-profit organizations provided that:

(1) Signs shall be erected no sooner than thirty (30) days prior and removed no later than seven (7) days after the event.

(2) No such sign shall exceed thirty-two (32) square feet.

(3) No such sign shall be illuminated.

(4) All such signs shall be located off the street right-of-way, unless otherwise granted permission for such location by the County or the Colorado Department of Transportation (CDOT). In no case may any such sign impede the view or travel of any motorists or pedestrians or be attached to any structure within the right-of-way (government signs, telephone poles, etc.)

7.1.7.24 No permit shall be required for text or copy changes on conforming or legal nonconforming signs specifically designed to permit changes of the text or copy; provided that no structural changes are made to the sign, and provided that the name of the business to which the sign belongs is not changed.

7.1.7.25 Signs displaying time and temperature devices provided they are not related to a product.

7.1.7.26 Signs for the control of traffic or other regulatory purposes including signs for the control of parking on private property, and official messages erected by, or on the authority of, a public officer in the performance of his/her duty.

7.1.7.27 Motor vehicle for sale signs provided there is only one (1) sign per vehicle, the sign does not exceed two (2) square feet, and the vehicles are located in approved sales lots.

7.2 NON-CONFORMING SIGNS

7.2.1 Applicability:

Nonconforming signs shall be removed or brought into conformance with these Regulations when:

7.2.1.1 More than fifty (50) percent of the reproduction cost of the sign or sign structure has been damaged or destroyed, or has deteriorated to such an extent that the cost of repairs exceed fifty (50) percent of the reproduction cost of the sign or sign structure.

7.2.1.2 The property undergoes development or redevelopment in accordance with Section 2 of these Regulations.

7.2.1.3 There is a change in the business name.

7.3 PROHIBITED SIGNS

7.3.1 Applicability:

Any sign not specifically listed as permitted by these Regulations is prohibited, including, but not limited to the following:

7.3.1.1 Any sign or sign structure which:

- (1)** In any other way obstructs the view of, may be confused with or purports to be an official traffic sign, signal or device or any other official sign;
- (2)** Uses any words, phrases, symbols or characters implying the existence of danger or the need for stopping or maneuvering a motor vehicle;
- (3)** Creates in any other way an unsafe distraction for motor vehicle operators; or
- (4)** Obstructs the view of motor vehicle operators entering a public roadway from any parking area, service drive, private driveway, alley or other thoroughfare.

7.3.1.2 Roof Signs.

7.3.1.3 Mechanical or electrical appurtenances, such as “revolving beacons”, that are designed to compel attraction.

7.3.1.4 Signs emitting sound, except for approved drive-up menu boards as provided for in Section 7.4.2.5.

7.3.1.5 Signs with intermittent or flashing illumination and animated or moving signs, except for time and temperature signs.

7.3.1.6 Awning mounted signs, unless painted directly on the face of the awning.

7.3.1.7 Pennants, banners, balloons, character likeness, flags, and similar displays except as provided in Section 7.7.4.

7.3.1.8 Temporary signs which advertise a business, commodity, service, entertainment, product, or attraction, except as permitted in Section 7.7.

7.3.1.9 Off-premise advertising signs, billboards or any other sign not pertinent and clearly incidental to the permitted use on the property where located, except for temporary

subdivision directional signs and political signs, and except for signs permitted in Section 7.7.

- 7.3.1.10** Any sign which interferes with free passage from or obstructs any downspout, window, door, stairway, ladder or opening intended as a means of ingress or egress or providing light or air.
- 7.3.1.11** Any sign located in such a way as to intentionally deny an adjoining property owner visual access to an existing sign.
- 7.3.1.12** Vehicle-mounted signs, including but not limited to, signs painted on or attached to semi-trailers or cargo containers when exhibited on private property adjacent to public right-of-way for the purpose of advertising the business or services offered on the property. Vehicle-mounted signs used in connection with a special event are exempted from the requirements of this section during the duration of the special event only. Upon the conclusion of the special event, such signs must be dismantled. For the purposes of this subsection, the term special event shall mean a parade, circus, fair, carnival, festival, farmers' market or other similar event that is different in character from the customary or usual activities generally associated with the property upon which the special event is to occur.
- 7.3.1.13** Inflatable freestanding signs or tethered balloons.
- 7.3.1.14** Portable signs except as provided in Section 7.7.
- 7.3.1.15** Signs that extend above or below the bottom of a fascia board or mansard roof.
- 7.3.1.16** Any sign (together with its supporting structure) now or hereafter existing which, ninety (90) days or more after the premises have been vacated, advertises an activity, business, product or service no longer produced or conducted upon the premises upon which such sign is located. If the sign or sign structure is covered or the identifying symbols or letters removed, an extension of time may be granted by the Building Official upon good cause for such extension being shown. (This provision shall not apply to permanent signs accessory to businesses which are open only on a seasonal basis, provided that there is clear intent to continue operation of the business).
- 7.3.1.17** Any sign or sign structure which:
- (1)** Is structurally unsafe;
 - (2)** Constitutes a hazard to safety or health by reason of inadequate maintenance or dilapidation;
 - (3)** Is not kept in good repair; or
 - (4)** Is capable of causing electrical shocks to persons likely to come in contact with it.

REGULATIONS SPECIFIC TO LAND USES**7.4.1 Agricultural and Residential Uses:****7.4.1.1 General:**

- (1) Freestanding signs shall not exceed a height of eight (8) feet, except that arched signs over a prominent entry may be up to twenty (20) feet high. A landscaped planter area of at least twenty-five (25) square feet is required.
- (2) Wall signs shall not exceed a height of fifteen (15) feet.
- (3) Only indirect illumination of signs is allowed.

7.4.1.2 Identification Signs:

- (1) Residence signs: One (1) or more wall or freestanding signs not to exceed a total aggregate area of three (3) square feet which may include the name of the residence, the name of the occupant, and the street address.
- (2) Commercial farm or ranch signs: One (1) or more freestanding or wall signs not to exceed a total aggregate area of forty (40) square feet which may include the name of the farm or ranch and a street address.
- (3) Multiple residence development, subdivision, and manufactured home park entrance signs: A maximum of two (2) freestanding signs with an aggregate area of forty (40) square feet shall be permitted at each entrance. The sign may include only the name of the development and the street address.

7.4.1.3 Non-commercial signs: On parcels less than five (5) acres, one (1) sign with a maximum area of twelve (12) square feet and a maximum height of six (6) feet. On parcels of five (5) acres or more, one (1) sign with a maximum area of thirty-two (32) square feet, and a maximum height of eight (8) feet.

7.4.1.4 Temporary signs in accordance with Section 7.7.

7.4.2 Commercial, Industrial, and other Non-Residential Uses:**7.4.2.1 General:**

- (1) Internally illuminated signs larger than forty (40) square feet shall have the copy in a lighter color than the background.
- (2) Multi-tenant projects (two or more tenants) shall submit a coordinated sign plan showing proposed materials, colors, and locations.

7.4.2.2 Wall, fascia, mansard, parapet, awning, projecting, and shingle identification signs:

- (1) Allowed only on the exterior elevation of the space occupied by the business, or, for shingle signs, immediately adjacent to the business it identifies.
- (2) The maximum sign area for each business is one (1) square foot for each linear foot of building elevation on which the sign is displayed.
- (3) Projecting signs shall be a maximum of twelve (12) square feet, non-illuminated, and project not more than thirty (30) feet from the wall.
- (4) The minimum clearance between the bottom of a shingle sign or a projecting sign and the nearest grade or sidewalk is seven and one half (7.5) feet.

7.4.2.3 Freestanding identification signs:

- (1) One (1) freestanding sign shall be permitted per project, or integrated center, except on parcels with multiple street frontages, one (1) sign may be permitted for each street if both frontages adjacent to the site are at least three hundred (300) feet.
- (2) The maximum height is fifteen (15) feet.
- (3) The maximum area for each sign is forty-eight (48) square feet on projects up to five (5) acres and eighty (80) square feet for projects over five (5) acres.
- (4) The base shall have an aggregate width of at least twenty-five (25) percent of the width of the sign. This may be a single support or not more than two (2) supports.
- (5) The sign or sign structure shall contain similar materials and colors as the building it identifies.

7.4.2.4 Reader panel signs:

- (1) Up to fifty (50) percent of the permitted freestanding sign area may be used for a reader panel sign.

7.4.2.5 Menu boards for drive-thru restaurants:

- (1) One (1) preview menu board and one (1) ordering menu board is allowed per business. Such signs may be freestanding or wall mounted.
- (2) The maximum aggregate area for a preview and an ordering menu board shall not exceed thirty-six (36) square feet with a maximum height of eight (8) feet.

7.4.2.6 Directional signs when required to assist the flow of traffic not to exceed six (6) square feet in area or three (3) feet in height.

7.4.2.7 Directory signs when required to identify the location of the various buildings or offices located within the project not to exceed eighteen (18) square feet and a maximum height of six (6) feet.

7.4.2.8 One (1) Non-commercial sign not to exceed twelve (12) square feet. The maximum height shall be six (6) feet for freestanding signs and fifteen (15) feet for wall signs.

7.4.2.9 Temporary signs in accordance with Section 7.7.

7.5 SIGN MEASUREMENT

7.5.1 Sign Surface Area:

The area of a geometric shape enclosing any message, logo, symbol, name, photograph or display face shall be measured using standard mathematical formulas. Time and temperature devices shall not be included within the measurement of maximum sign area.

FIGURE 7-1

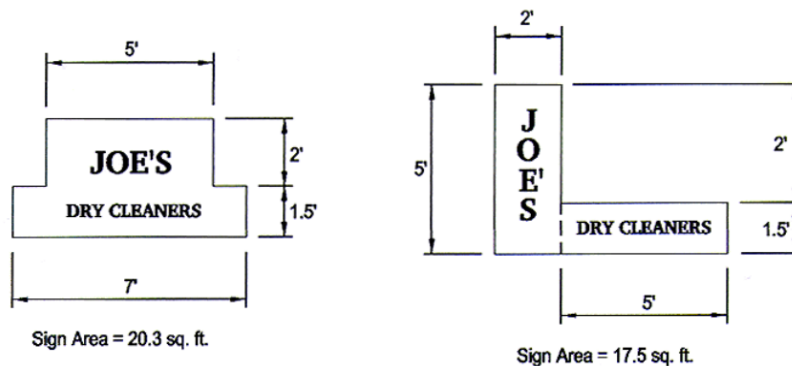

SIGN AREA MEASUREMENT

7.5.2 Sign Support:

Supporting framework or bracing that is clearly incidental to the display itself shall not be computed as sign area.

7.5.3 Back-to-Back (Double-Faced) Signs:

Back-to-back signs shall be regarded as a single sign only if mounted on a single structure, and the distance between each sign face does not exceed two (2) feet at any point.

7.5.4 Three-Dimensional Signs:

Where a sign consists of one or more three-dimensional objects (i.e. balls, cubes, clusters of objects, sculpture), the sign area shall be measured as their maximum projection upon a vertical plane.

7.5.5 Wall Signs:

If a sign is attached to a wall, only that portion of the wall onto which the sign face or letters are placed shall be calculated in the sign area.

7.5.6 Sign Height:

The height of a sign shall be measured from the highest point of a sign to the ground surface beneath it. When berms are used in conjunction with signage, the height of the sign shall be measured from the mean elevation of the fronting street.

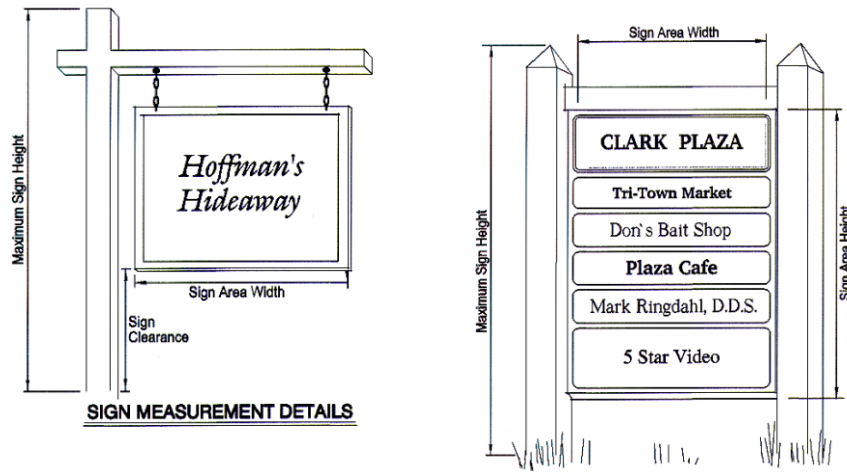
FIGURE 7-2**7.6 SIGN DESIGN****7.6.1 Design compatibility:**

7.6.1.1 Creative design encouraged. Signs shall make a positive contribution to the general appearance of the street and commercial area in which they are located. A well-designed sign can be a major asset to a building. Archuleta County encourages imaginative and innovative sign design. The creative sign is specifically designed for artistic and unusual signs that might not fit the standard sign regulations and categories.

7.6.1.2 Professional. Signs shall be made by a professional sign company or other qualified entity.

7.6.1.3 Proportionate size and scale. The scale of signs shall be appropriate for the building on which they are placed and the area in which they are located. Building signs shall be harmonious in scale and proportion with the building facade they are mounted to.

7.6.1.4 Sign location and placement

(1) Visibility – Signs shall not visually overpower nor obscure architectural features.

FIGURE 7-3



- (2) Integrate signs with the building and landscaping – Carefully coordinate the sign with the architectural design, overall color scheme and landscaping. Signs shall be designed to complement or enhance the other signs for a building.
- (3) Unified sign band – Whenever possible, signs located on buildings with the same blockface shall be placed at the same height, in order to create a unified sign band. Locate wall signs at the first floor level only for retail uses.
- (4) Monument signs – Locate monument signs in a planter setting within a landscaped area at the primary entries to residential, commercial and industrial subdivisions to provide an overall project identity. A maximum of one (1) monument sign per entry is permitted.
- (5) Pedestrian-oriented signs – Pedestrian-oriented signs are encouraged. It is desirable to include a pedestrian-oriented sign as one of the permitted signs for a business. These signs are designed for and directed toward pedestrians so they can easily and comfortably read the sign as they stand adjacent to the business.
- (6) Road right-of-way – No sign shall be erected within the road right-of-way or near the intersection of any road(s) or driveways in such a manner as to obstruct free and clear vision of motorists or pedestrians or at any location where, by reason of the position, shape or color, it may interfere with, obstruct the view of, or be confused with any authorized traffic sign, signal or device. Signs located at an intersection must be outside of the sight distance triangle.

7.6.1.5 Landscaping. Freestanding signs shall be landscaped at their base in a way harmonious with the landscape concept for the whole site. Landscaping shall form an attractive, dense cluster at the base of the sign that is equally attractive in winter and summer.

FIGURE 7-4

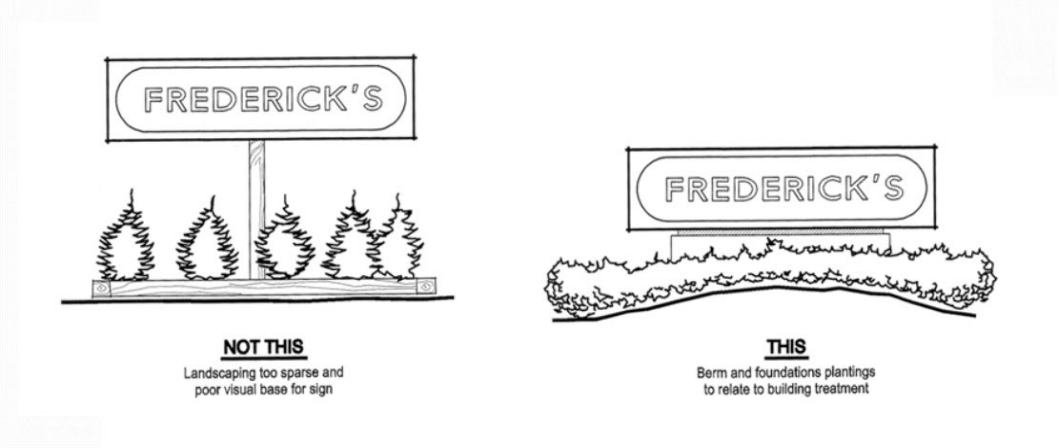

7.6.1.6 Reduce sign impact. Because residential and commercial uses generally exist in close proximity, signs shall be designed and located so that they have little or no impact on adjacent residential neighborhoods. Small-scale signs are encouraged.

FIGURE 7-5



REDUCE SIGN IMPACT

7.6.2 Color:

7.6.2.1 Select colors carefully. Colors shall be selected to contribute to legibility and design integrity. Sign colors shall complement the colors used on the structures and the project as a whole. Colors or combinations of colors that are harsh and disrupt the visual harmony and order of the street are unacceptable.

7.6.2.2 Use contrasting colors. Provide a substantial contrast between the color and the material of the background and the letters or symbols to make the sign easier to read during both the day and night. Light letters on a dark background or dark letters on a light background are most legible.

7.6.2.3 Avoid using too many colors. Colors or color combinations that interfere with legibility of the sign copy or that interfere with viewer identification of other signs shall be avoided.

7.6.3 Materials:

7.6.3.1 Signs shall be constructed of durable, high quality architectural materials. The sign package must use materials, colors and designs that are compatible with the building facade. Sign materials must be of proven durability. Treated wood, painted metal, stone, brick and stucco are the preferred materials for signs.

7.6.4 Legibility:

Signs shall be adequately legible under the circumstances in which they are primarily seen. The legibility of signs is related to:

7.6.4.1 The speed at which they are viewed;

7.6.4.2 The context and surroundings in which they are seen; and

7.6.4.3 The design, colors and contrast of the sign copy and sign face.

7.6.4.4 The design of the sign including copy, lettering size and style, and colors shall logically relate to the average speed of the traffic which will see it. Signs shall legibly convey their messages without being distracting or unsafe to motorists reading them. Symbols and logos can be used in place of words whenever appropriate.

7.6.5 Sign Illumination:

7.6.5.1 Use illumination only if necessary.

7.6.5.2 Sign illumination shall complement, not overpower, the overall composition of the site, and shall comply with Section 5.4.4, the Outdoor Lighting provisions of these Regulations.

7.6.5.3 Use a direct light source. All lighted signs shall have their lighting directed in such a manner as to illuminate only the face of the sign. When external light sources are directed at the sign surface, the light source must be concealed from pedestrians' and motorists' "lines of sight."

7.6.5.4 Signs must be illuminated in a way that does not cause glare onto the street and adjacent properties. Signs shall be lighted only to the minimum level for nighttime readability.

7.6.5.5 All lighted signs shall meet all applicable electrical codes and the electrical components used shall bear the label of an approval agency. Additionally, electrical permits shall be obtained for electric signs.

7.6.5.6 Flashing, moving, blinking, chasing or other animation effects shall be prohibited on all signs except time and temperature signs.

7.6.5.7 Neon tubing is an acceptable method of sign illumination for window signs in commercial districts.

7.6.5.8 The use of individually-cut, back-lit letter signs is encouraged.

7.6.5.9 No commercial sign within five hundred (500) linear feet of a pre-existing residential structure may be illuminated between the hours of 11:00 p.m. and 6:00 a.m. A residence shall be deemed “pre-existing” for purposes of this Section if it has a valid building permit in effect for construction of said structure or if construction of said structure was complete on or prior to the effective date of these Regulations.

7.7 STANDARDS FOR SPECIFIC SIGN TYPES

7.7.1 Real Estate Signs, Lease, or Rent Signs:

Signs shall be non-illuminated, with one (1) sign permitted for each street frontage, with a maximum of two (2) signs per parcel or building.

7.7.1.1 Agricultural and Residential Uses:

- (1)** Less than three (3) acres, each sign shall have a maximum area of six (6) square feet and a maximum height of five (5) feet.
- (2)** Three to ten (3-10) acres, each sign shall have a maximum area of twelve (12) square feet and a maximum height of six (6) feet.
- (3)** Over ten (10) acres, each sign shall have a maximum area of thirty-two (32) square feet, and a maximum height of eight (8) feet.

7.7.1.2 Commercial, Industrial, other Non-residential Uses:

- (1)** Vacant land: Less than two (2) acres, each sign shall have a maximum area of twelve (12) square feet and a maximum height of six (6) feet. Two (2) acre or larger, each sign shall have a maximum area of thirty-two (32) square feet and a maximum height of eight (8) feet.
- (2)** Buildings: Each sign shall have a maximum area of twelve (12) square feet and a maximum height of six (6) feet.

7.7.2 Off-site Open House or Other Directional Signs:

7.7.2.1 A maximum of two (2) signs is permitted for each open house or directional sign for the sale of property.

7.7.2.2 Each sign shall have a maximum area of six (6) square feet and a maximum height of three (3) feet.

7.7.2.3 Signs shall be posted for a maximum of forty-eight (48) hours per week.

7.7.2.4 Signs must be placed on private property and with the permission of the owner or lessee of the property.

7.7.3 Subdivision Advertising Signs:

7.7.3.1 One (1) sign is permitted at each major entry with a maximum of two (2) signs per subdivision.

7.7.3.2 Each sign shall have a maximum area of thirty-two (32) square feet and a maximum height of eight (8) feet.

7.7.3.3 Portable signs are not allowed.

7.7.3.4 No sign permit shall be issued until the Board of County Commissioners has conditionally approved a final plat or a survey map has been filed for parcels greater than thirty five (35) acres.

7.7.3.5 Such signs may be maintained until all of the lots in the subdivision are sold or for three (3) years, whichever occurs first. Signs may be renewed after three (3) years if the lots are not sold out.

7.7.3.6 A real estate agent may add their company name, agent name, and phone number(s) to a subdivision advertising sign, but shall only place real estate signs on lots that are for sale within the advertised subdivision.

7.7.3.7 No real estate sign shall be placed at the entrance to a subdivision or on the subdivision advertising sign.

7.7.4 Special Events, Grand Openings:

7.7.4.1 May be used to advertise grand openings, a change of business ownership, special sales, new products or services, customary seasonal events, and other similar promotions.

7.7.4.2 May include such displays as pennants, banners, flags, inflatable structures, character or product likeness, and other similar attention attracting media and devices.

7.7.4.3 Special event displays shall be allowed for a maximum of ten (10) consecutive days no more than four (4) times per year, except that Christmas tree sales lots may have signage from Thanksgiving to December 31.

7.7.4.4 Grand opening displays are allowed for thirty (30) consecutive days. The grand opening display requires a new business or change in business name.

7.7.4.5 There shall be a minimum of thirty (30) days between each display.

7.7.5 Seasonal Sales, Temporary Uses (with Proper Permit):

One (1) non-illuminated identification sign is allowed with a maximum area of thirty-two (32) square feet and a maximum height of eight (8) feet.

7.7.6 Construction and Development Signs:

7.7.6.1 Portable signs are not allowed.

7.7.6.2 The signs may identify the name of the project, the names of the developer, contractor, architect, subcontractor, and financier of the project, and the projected completion date.

7.7.6.3 The signs may only be installed after building permits have been issued for the project.

7.7.6.4 The signs shall be removed prior to the issuance of a Certificate of Occupancy for the project.

7.7.7 Window Signs:

May be used for business identification and advertising of any service, product, person, business, place or activity on the premises.

7.7.8 Political Signs:

7.7.8.1 Agricultural and residential uses: A maximum area of six (6) square feet and a maximum height of five (5) feet.

7.7.8.2 Commercial, Industrial and Non-Residential uses: A maximum area of thirty-two (32) square feet and a maximum height of eight (8) feet.

7.7.8.3 Political signs advocating a position for a specific candidate or measure shall not be displayed more than sixty (60) days prior to an election and shall be removed within ten (10) days following the appropriate election.

7.8 INSTALLATION AND MAINTENANCE

7.8.1 Installation:

7.8.1.1 All signs shall be mounted so that the method of installation is concealed.

7.8.1.2 Projecting signs shall be mounted so they generally align with others in the block.

7.8.1.3 All signs and all components thereof, including sign structures and sign faces, shall be kept neatly painted, in a good state of repair and in compliance with all building and electrical codes. Archuleta County may inspect any sign governed by these Regulations and shall have the authority to order the painting, repair, alteration or removal of a sign

which constitutes a hazard to safety, health or public welfare by reason of inadequate maintenance, dilapidation or obsolescence.

7.8.1.4 Owners of projecting signs extending over public right-of-way shall be required to maintain public liability insurance in an amount to be determined appropriate by Archuleta County, in which the County is named as an “other insured.”

7.8.2 Maintenance:

7.8.2.1 The owner of a sign and the owner of the premises on which such sign is located shall be jointly and severally liable to maintain such sign, including any illumination sources in neat and orderly condition, and in a good working order at all times, and to prevent the development of any rust, corrosion, rotting or other deterioration in the physical appearance or safety of such sign. The sign must also be in compliance with all building and electrical codes.

7.8.2.2 The owner of any sign regulated by these Regulations shall be required to keep signs and supporting hardware, including temporary signs and time/temperature signs structurally safe, clean, free of visible defects and functioning properly at all times. Repairs to signs shall be equal to or better in quality of materials and design than the original sign.

7.8.2.3 Archuleta County may inspect any sign governed by these Regulations and shall have the authority to order the painting, repair, alteration or removal of a sign which constitutes a hazard to safety, health or public welfare by reason of inadequate maintenance, dilapidation or obsolescence.

This page left blank for double-sided printing.